

smartSWITCH HF 5DP f

Automatic switching based on motion and light level



Product description

- _ Motion detector for luminaire installation
- _ Motion detection through glass and thin materials (except metal)
- _ For automatic on/off switching of luminaires with electronic ballasts and LED Drivers
- _ Bright-out function: luminaire is not switched on if there is adequate brightness
- _ Delay time, detection range and light value for the bright-out function can be set via 9 dip switches
- _ Max. installation height 5 m
- _ Two housing options allowing flexible installation
- _ Variable detection area (100 – 10 %)
- _ Zero cross switching supported
- _ 5 years guarantee

Website

<http://www.tridonic.com/28002214>



smartSWITCH HF 5DP f

Automatic switching based on motion and light level

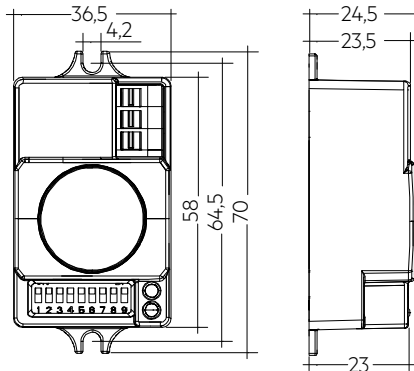
**Ordering data**

Type	Article number	Dimensions L x W x H	Packaging, carton	Weight per pc.
smartSWITCH HF 5DP f	28002214	70 x 36.5 x 24.5 mm	5 pc(s).	0.04 kg

Technical data

Rated supply voltage	220 – 240 V
Mains frequency	50 Hz
Power	< 0.5 W
Frequency	5.8 GHz (± 75 MHz)
Transmission power	< 0.2 mW
Load resistive	800 W
Load capacitive	400 VA
Detection angle	30 – 150°
Max. detection area	ø 7 m
Max. mounting height	5 m
tc	85 °C
Ambient temperature ta	-20 ... +70 °C
Storage temperature ts	-20 ... +70 °C
Humidity	min. 5 ... max. 85 % at 30 °C
Type of protection	IP20
Protection class	Protection class II
Housing material	PC, halogen-free
Housing colour	RAL 9016 (white)

Approval marks**Standards**

EN 61347-1, EN 61347-2-11, EN 300 440-2 V1.4.1, EN 301 489-3 V1.6.1, EN 62479, EN 55015, EN 61000-3-2, EN 61000-3-3, EN 61547